

DRAWN BY : XXX

DATE : XX/XX/XX

JOB NO : XXXXX

SHEET X OF X

PROJECT : XXXXXXXXXXXX VP PIT ALUM FRAM DRAIN PAN STD

MODEL: KDVP ALUM. ENTRANCE GRID W/VINYL INSERTS, EMBEDDED ALUM FRAME, DRAIN PAN - PIT APPLICATION



8333 BOYLE PARKWAY TWINSBURG, OHIO 44087  
(800) 321-3827 TEL (440) 439-8650 FAX (440) 439-6889

ELEVATED AND ISO DRAIN PAN VIEWS

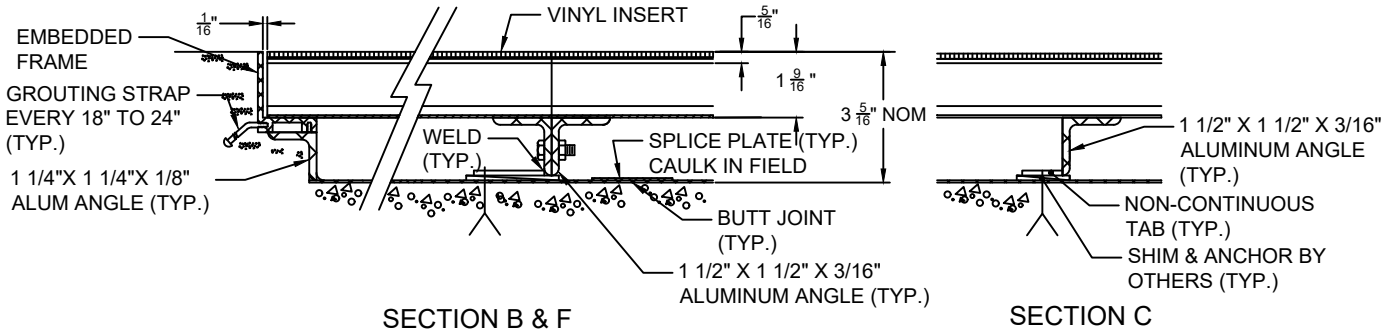
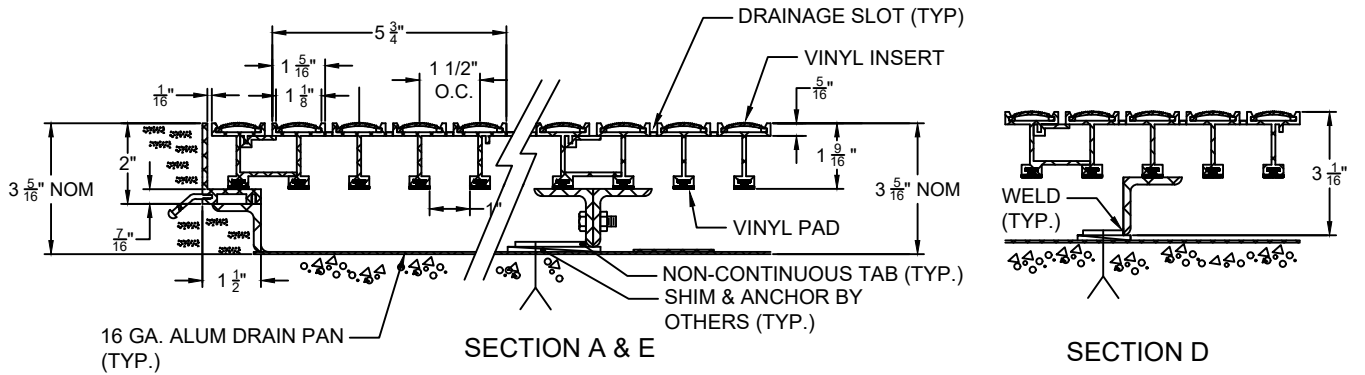
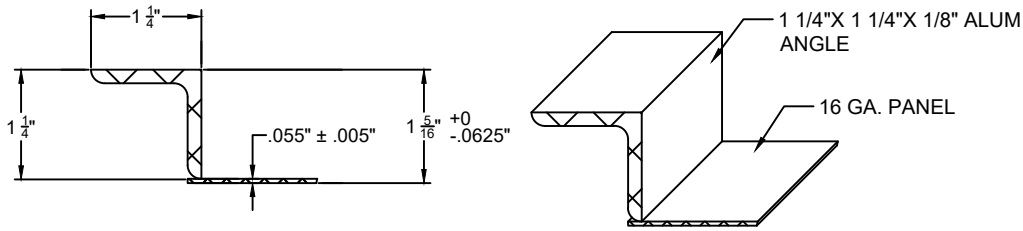

STANDARD SPECIFICATIONS :

1. MAT SURFACE : VINYL TREADS ARE MADE OF PVC, SERRATED, NON-SLIP SURFACE WITH A CONVEX DESIGN.
2. GRID MATERIAL : EXTRUDED ALUMINUM (ALLOY 6063-T6)
3. FRAMES: EXTRUDED ALUMINUM (ALLOY 6063-T6)
4. FILLER (AS REQUIRED) : EXTRUDED BLACK VINYL
5. MANUFACTURING TOLERANCES :

FRAME: +0" / -0.125"  
MAT: + 0" / - 0.125"

NOTE :

FRAME FINISH : MILL

GRID FINISH : MILL

VINYL COLOR :

DRAIN PAN DIMENSIONS FOR REFERENCE ONLY; CUT TO FIT.

NOTE: DO NOT SCALE DRAWING.

VP 9/20/17