

DRAWN BY : XXX

DATE : XX/XX/XX

JOB NO : XXXXX

SHEET X OF X

PROJECT : XXXXXXXX

BR PIT FRAME PAN STD

MODEL : KDBR BRONZE BAR GRATING W/ HIDDEN LOCKING DEVICES, BRONZE ANGLE FRAME, SS LEGDOWN FRAME, SS DRAIN PAN - PIT APPLICATION



8333 BOYLE PARKWAY TWINSBURG, OHIO 44087  
(800) 321-3827 TEL (440) 439-8650 FAX (440) 439-6889

GENERAL SPECIFICATIONS : KDBR

CONSTRUCTION :

1. THE TREAD MATERIAL SHALL BE OF MILL FINISH EXTRUDED ARCHITECTURAL BRONZE ALLOY (C38500) WITH 0.815" x 0.25" BRONZE TREAD BARS ASSEMBLED WITH NYLON SPACERS AND 1/4" THREADED STAINLESS STEEL RODS AND NUTS.
2. STANDARD SLOT OPENING SHALL BE 1/4".
3. SPACING OF STAINLESS STEEL THREADED RODS TO BE 10" ON CENTER (TYPICAL).
4. HIDDEN LOCKING DEVICES WILL FASTEN GRATING TO THE FRAME.
5. FRAMES : ARCHITECTURAL BRONZE (ALLOY C38500).
6. MANUFACTURING TOLERANCES :

GRATE : + 0" / - 0.250"  
FRAME : + 0" / - 0.125"

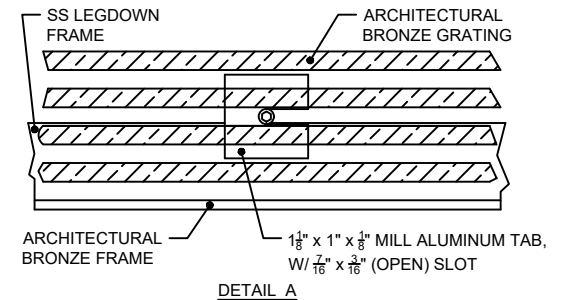
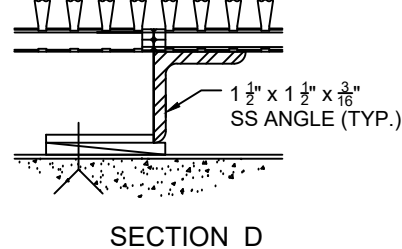
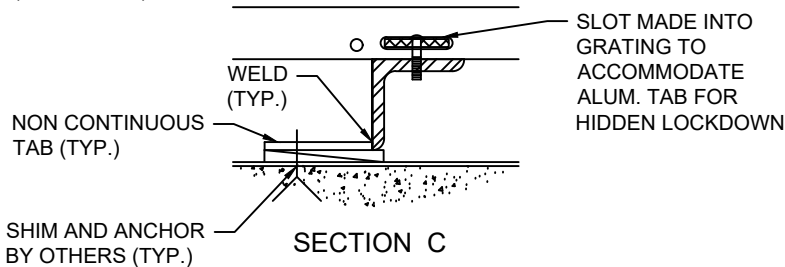
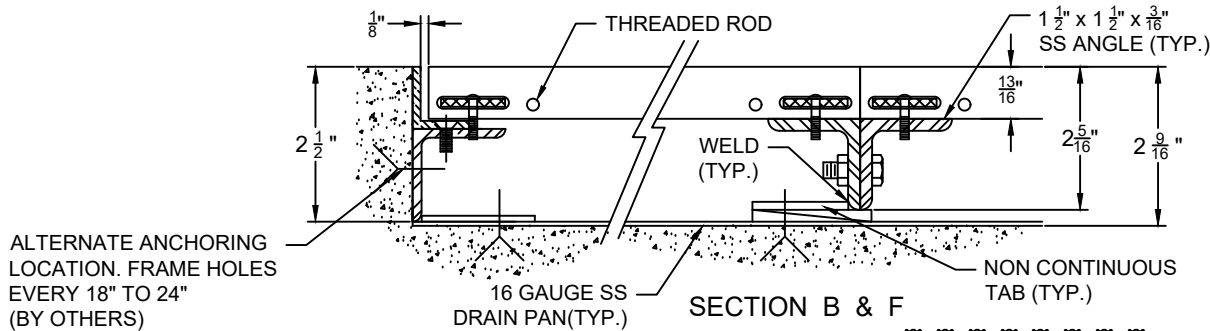
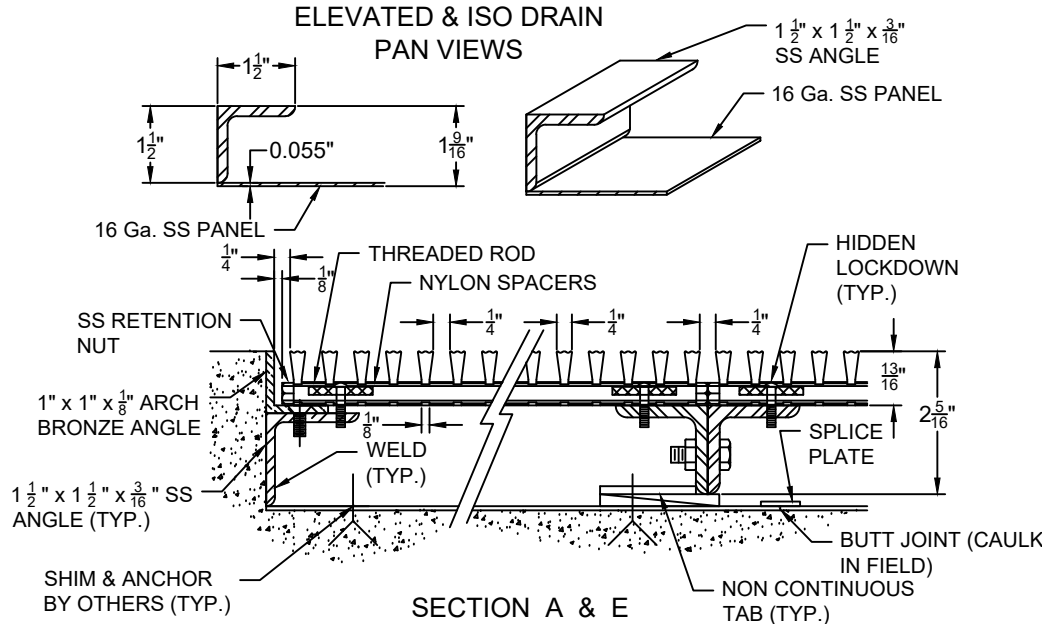

DRAIN PAN DIMENSIONS FOR REFERENCE ONLY; CUT TO FIT.

NOTE : DO NOT SCALE DRAWING.

BR 3/13/17