

DRAWN BY : XXX

DATE : XX/XX/XX

JOB NO : XXXXX

SHEET X OF X

PROJECT : XXXXXXX

ALI ALUM PIT FRAME STD

MODEL : KDALI ALUM BAR GRATING W/ HIDDEN LOCKING DEVICES, ALUM ANGLE FRAME - PIT APPLICATION



8333 BOYLE PARKWAY TWINSBURG, OHIO 44087
TEL (800) 321-3827

GENERAL SPECIFICATIONS : KDALI

CONSTRUCTION :

1. THE TREAD MATERIAL SHALL BE OF MILL FINISH EXTRUDED ALUMINUM ALLOY (6063-T6) WITH 1.06" x 0.186" ALUMINUM TREAD BARS
2. SWAGED ALUMINUM CROSS BAR FROM EXTRUDED ALUMINUM ALLOY (6063-T1). STANDARD SLOT OPENING SHALL BE 3/4".
4. HIDDEN LOCKING DEVICES WILL FASTEN GRATING TO THE FRAME. HIDDEN LOCKDOWNS SHALL BE SPACED NO GREATER THEN 2'0" ON CENTER
5. FRAMES : EXTRUDED ALUMINUM (ALLOY 6063-T6)
6. MANUFACTURING TOLERANCES :
GRATE : + 0" / - 0.250"
FRAME : + 0" / - 0.125"

NOTE :

GRATE : MILL FINISH

FRAME : MILL FINISH

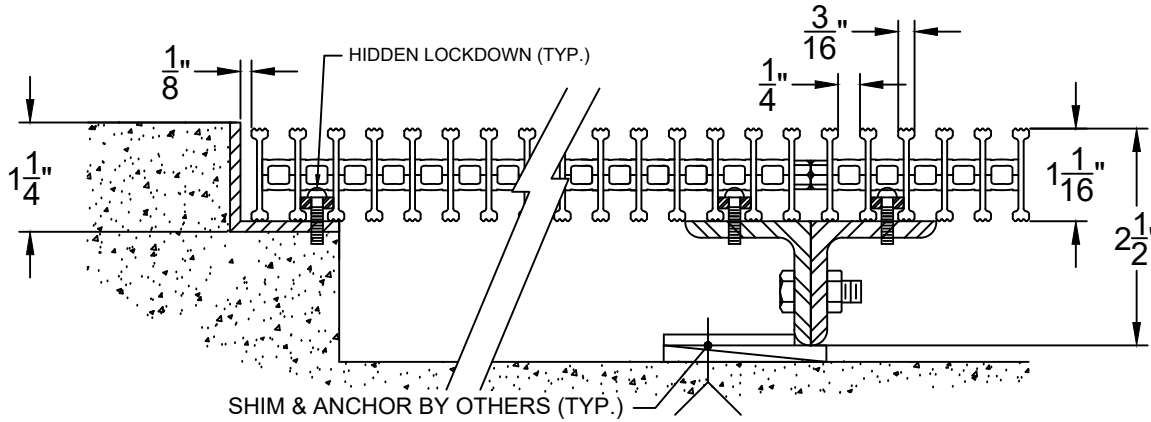

SECTION A & E

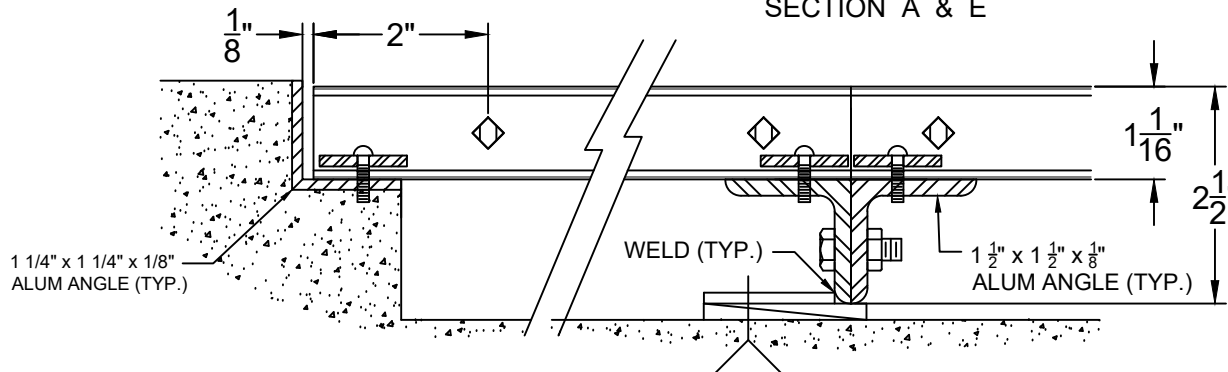

SECTION B & F

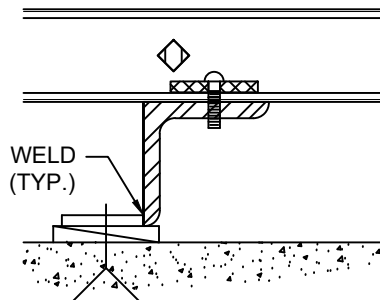

SECTION C

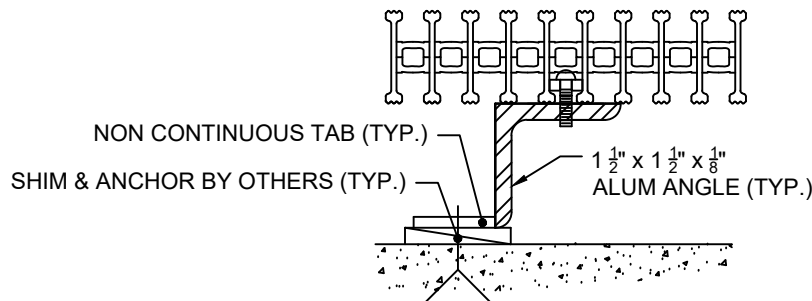

SECTION D

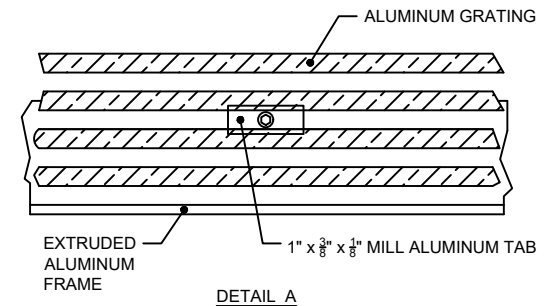

DETAIL A