

DRAWN BY : XXX

DATE : XX/XX/XX

JOB NO : XXXXX

SHEET X OF X

PROJECT : XXXXXXXX

MODEL: KD38 SS GRATING W/HIDDEN LOCKING DEVICES, ALUM ANGLE FRAME - LEVEL BED APPLICATION STD MILL FRAME

1) ASSEMBLE FRAMES IN FIELD

2) PREPARE PIT FOR COPLANAR INSTALLATION OF PIT LINER (DETAIL X)



8333 BOYLE PARKWAY TWINSBURG, OHIO 44087
(800) 321-3827 TEL (440) 439-8650 FAX (440) 439-6889

GENERAL SPECIFICATIONS : KD38

TREAD MATERIAL : TYPE 304 SS 0.090" x 0.138"
#4 SATIN FINISH SPACE 0.125" ; SPACING +/- 0.005"

SUPPORT RODS : 0.281"DIA. SPACED 2" O.C.

CONSTRUCTION : EACH JUNCTURE OF SURFACE WIRES TO SUPPORT RODS SHALL HAVE ELECTRIC RESISTANCE WELDED JOINTS.

OVERALL DIMENSION TOLERANCES :

GRATING : + 0", - 0.125", FRAME : + 0", - 0.125"

MANUFACTURING TOLERANCES :
ANSI/NAAMM A202.1-MBG 531 APPLICABLE TO :
ON CENTER MEASUREMENT OF TREAD MATERIAL
DIAGONAL MEASUREMENTS (SQUARE)
TRANSVERSE BOW (BEFORE FASTENING)
LONGITUDINAL BOW (BEFORE FASTENING)

MATERIAL TOLERANCES :
ASTM A484/A484M APPLICABLE TO SS ANGLES
ASTM B221 APPLICABLE TO ALUM SHAPES

SPECIAL NOTES :

*GC/INSTALLER IS RESPONSIBLE FOR COPLANAR INSTALLATION OF MAT SURFACE TO SURROUNDING FLOOR CONDITIONS
*GIVEN THAT THE NUMBER OF SURFACE WIRES (TREAD MATERIAL) IN ONE FOOT IS ABOUT SIXTY, IT IS PROBABLE THAT ADJACENT PANELS' WIRES WILL NOT ALIGN IN EVERY CASE. IN MOST CASES, THE WIRES WILL ALIGN FOR SEVERAL INCHES THEN APPEAR TO WALK. THIS IS UNAVOIDABLE MANIFESTATION OF THE MANUFACTURING PROCESS. THIS CONDITION APPLIES TO THE SUPPORT RODS AS WELL. SIMILARLY IN MITERED CORNERS, THE VARIANCES OF SLOTS WITHIN THE NORMAL TOLERANCE RANGES PRECLUDES GUARANTEED ADJACENT PANEL WIRE ALIGNMENT.

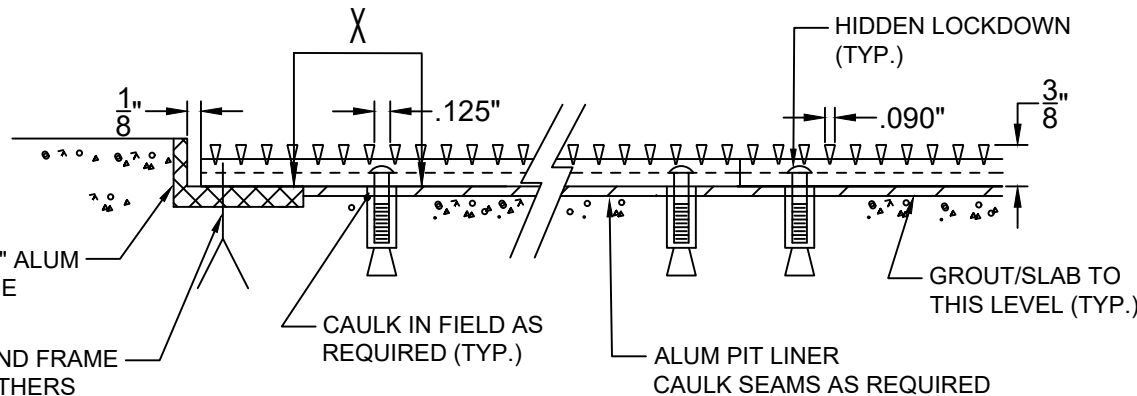

SECTION A

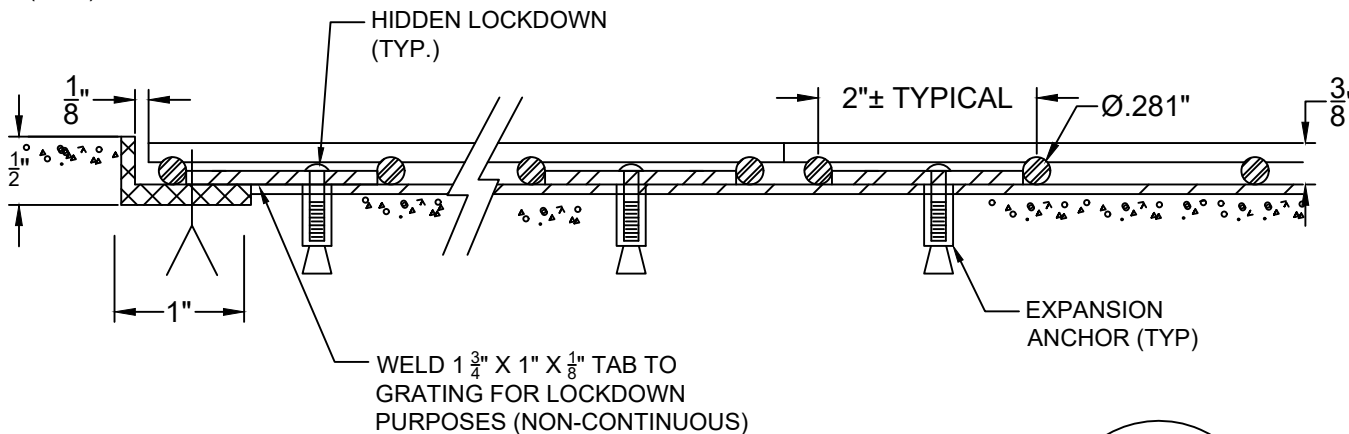

SECTION B

PRODUCT MAY NOT COME TO A COMPLETE POINT WELD IN FILLER (AS NEEDED)

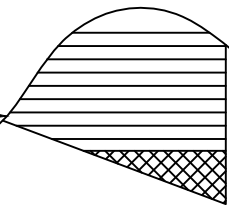

DETAIL X

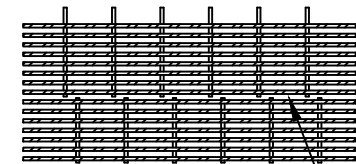

SUPPORT RODS MAY NOT ALIGN

DETAIL A

MODEL: KD38 IS DESIGNED TO REST DIRECTLY ON THE RECESS FLOOR. (IT WILL NOT SPAN) PIT LINERS ARE CUSTOM DRAIN PAN DIMENSIONS FOR REFERENCE ONLY; CUT TO FIT.

NOTE : DO NOT SCALE DRAWING.

38 3/8/17