

DRAWN BY : XXX

DATE : XX/XX/XX

JOB NO : XXXXX

SHEET X OF X

PROJECT : XXXXXXXX

VM ALUM ANGLE FRAME STD

MODEL : KDVM ALUM ROLLOUT MAT W/ VINYL INSERTS - ALUMINUM ANGLE FRAME

KADEE INDUSTRIES, INC.

7160 KRICK ROAD WALTON HILLS, OHIO 44146
(800) 321-3827 TEL (440) 439-8650 FAX (440) 439-6889

STANDARD SPECIFICATIONS : KDVM

1. MAT SURFACE : VINYL TREADS ARE MADE OF PVC, SERRATED, NON-SLIP SURFACE WITH A CONVEX DESIGN.
2. MAT MATERIAL : EXTRUDED ALUMINUM (ALLOY 6063-T6)
3. FRAMES : EXTRUDED ALUMINUM (ALLOY 6063-T6)
4. FILLER (AS REQUIRED) : EXTRUDED BLACK VINYL
5. MANUFACTURING TOLERANCES :

FRAME : + 0" / - 0.125"

MAT : + 0" / - 0.125"

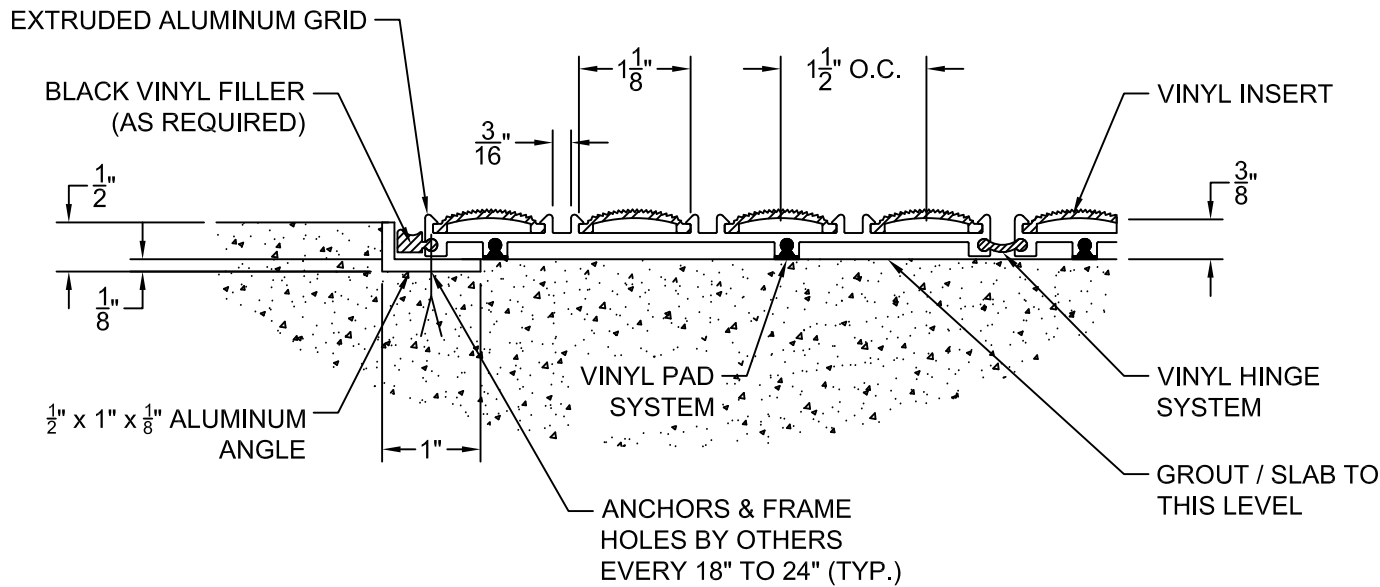

SECTION A

NOTE :

FRAME FINISH : MILL

GRID FINISH : MILL

VINYL COLOR :