

DRAWN BY : XXX

DATE : XX/XX/XX

JOB NO : XXXXX

SHEET XX OF XX

PROJECT : XXXXXXXX

58 SS FRAME STD

MODEL : KD58 SS GRATING W/HIDDEN LOCKING DEVICES, SS FRAME - LEVEL BED APPLICATION

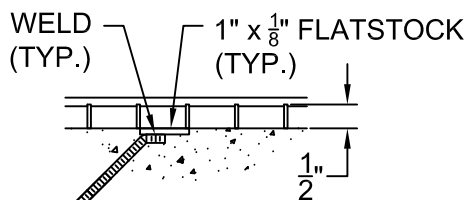
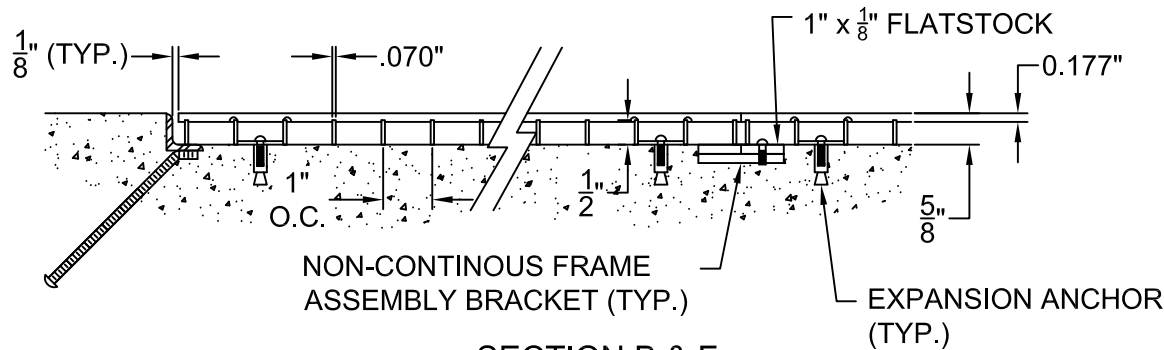
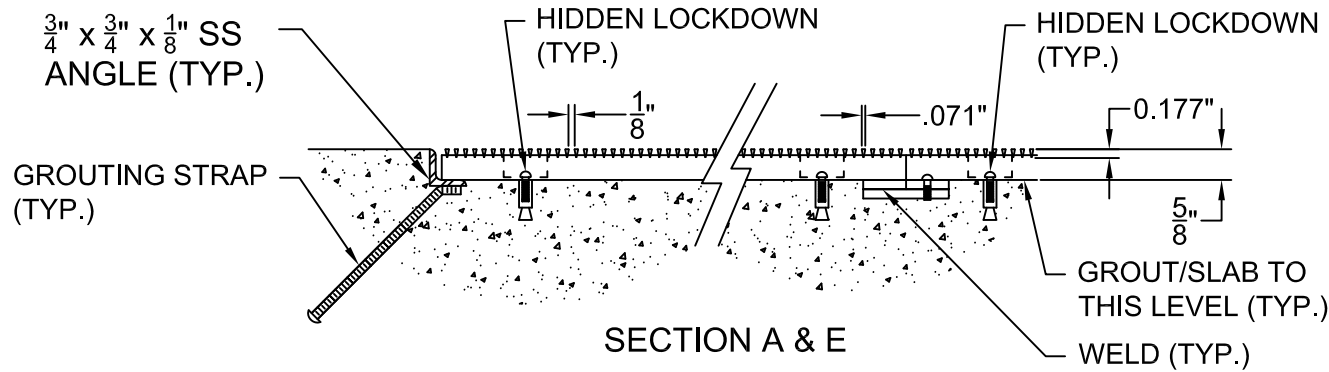

SECTION C

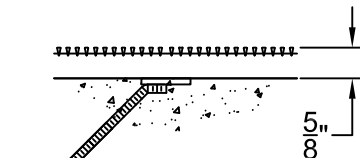

SECTION D

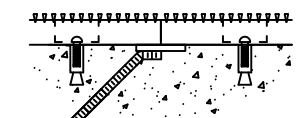

SECTION E1

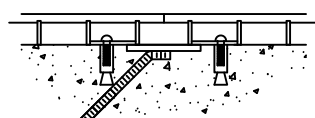

SECTION F1

PRODUCT MAY NOT COME TO A COMPLETE POINT; WELD IN FILLER (AS NEEDED)

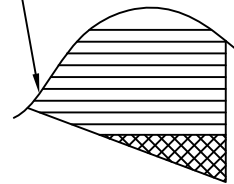

DETAIL X

KADEE INDUSTRIES, INC.

7160 KRICK ROAD WALTON HILLS, OHIO 44146
(800) 321-3827 TEL (440) 439-8650 FAX (440) 439-6889

GENERAL SPECIFICATIONS : KD58

TREAD MATERIAL : TYPE 304 SS 0.071" x 0.177"
#4 SATIN FINISH SPACE 0.125" ; SPACING +/- 0.005"

SUPPORT RODS : 0.070" x 0.5" SPACED 1" O.C.

CONSTRUCTION : EACH JUNCTURE OF SURFACE WIRES TO SUPPORT RODS SHALL HAVE ELECTRIC RESISTANCE WELDED JOINTS.

OVERALL DIMENSION TOLERANCES :

GRATING : + 0", - 0.125", FRAME : + 0", - 0.125"

MANUFACTURING TOLERANCES :

ANSI/NAAMM A202.1-MBG 531 APPLICABLE TO :
ON CENTER MEASUREMENT OF TREAD MATERIAL
DIAGONAL MEASUREMENTS (SQUARE)
TRANSVERSE BOW (BEFORE FASTENING)
LONGITUDINAL BOW (BEFORE FASTENING)

MATERIAL TOLERANCES :

ASTM A484/A484M APPLICABLE TO SS ANGLES
ASTM B221 APPLICABLE TO ALUM SHAPES

SPECIAL NOTES :

*GC/INSTALLER IS RESPONSIBLE FOR COPLANAR INSTALLATION OF MAT SURFACE TO SURROUNDING FLOOR CONDITIONS
*GIVEN THAT THE NUMBER OF SURFACE WIRES (TREAD MATERIAL) IN ONE FOOT IS ABOUT SIXTY, IT IS PROBABLE THAT ADJACENT PANELS' WIRES WILL NOT ALIGN IN EVERY CASE. IN MOST CASES, THE WIRES WILL ALIGN FOR SEVERAL INCHES THEN APPEAR TO WALK. THIS IS UNAVOIDABLE MANIFESTATION OF THE MANUFACTURING PROCESS. THIS CONDITION APPLIES TO THE SUPPORT RODS AS WELL. SIMILARLY IN MITERED CORNERS, THE VARIANCES OF SLOTS WITHIN THE NORMAL TOLERANCE RANGES PRECLUDES GUARANTEED ADJACENT PANEL WIRE ALIGNMENT.

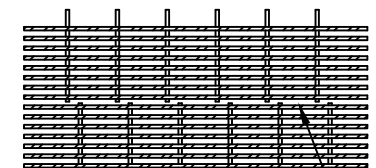

SUPPORT RODS MAY NOT ALIGN

DETAIL A

HIDDEN LOCKDOWNS ARE LOCATED AT STARS (*) ON GRATING USE ALL LOCKDOWNS PROVIDED. SEAMS IN GRATING MAY NOT ALIGN WITH SEAMS IN FRAMING IN ALL CASES. KD58 MUST REST DIRECTLY ON THE RECESS FLOOR (IT WILL NOT SPAN).